

# T-7601AH PISTOL GRIP WELD FLUX SCALER

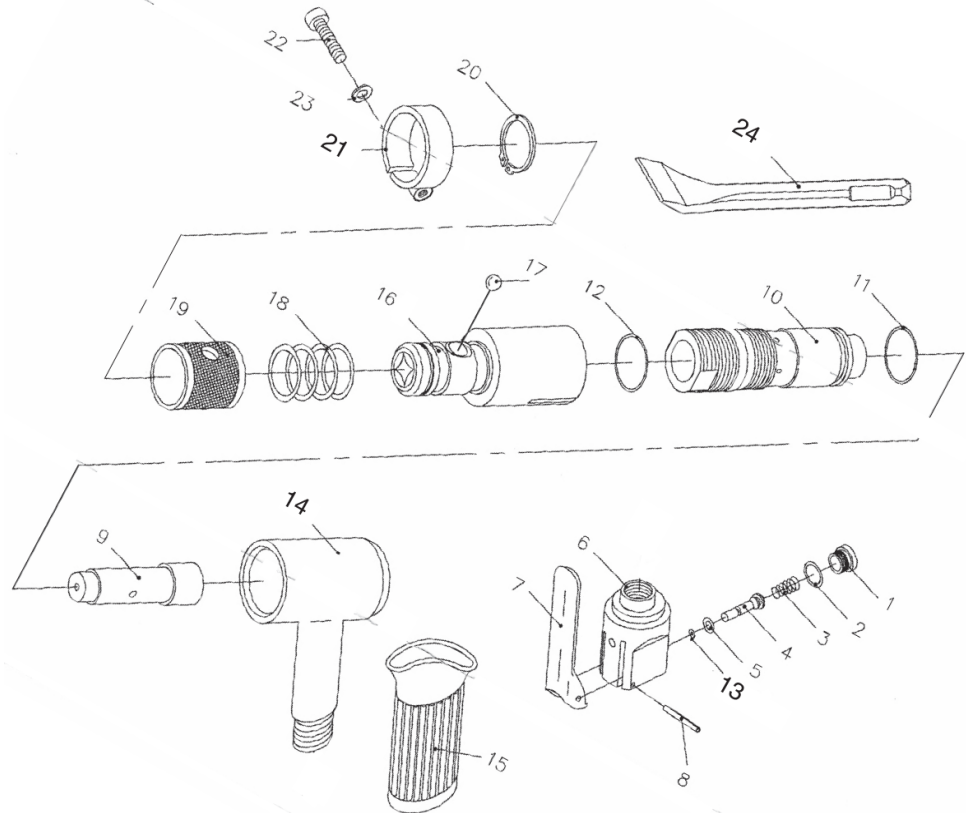

**OILING INSTRUCTIONS:**  
**OIL AFTER EACH USE WITH A FEW DROPS OF AIRTOOL OIL THROUGH THE AIR INLET.**  
**RUN FOR 1 SECOND TO COAT ALL INTERNAL PARTS**



**USE 90 PSI MAXIMUM**

REF #	PART #	DESCRIPTION	QTY	REF #	PART #	DESCRIPTION	QTY
1	760101	VALVE CAP	1	16	7601AH16	CYLINDER BODY	1
2	760102	O-RING	1	17	7601AH17	BALL	1
3	760103	VALVE SPRING	1	18	7601AH18	O-RING	4
4	760104	VALVE STEM	1	19	7601AH19	CHISEL COVER	1
5	760105	O-RING	1	20	7601AH20	SNAP RING	1
6	760106	VALVE BODY	1	21	7601AH21	CLAMP	1
7	760107	THROTTLE LEVER	1	22	7601AH22	HEX BOLT	1
8	760108	ROLL PIN	1	23	7601AH23	WASHER	1
9	760109	PISTON	1	24	T-7601AH8	1-1/4" ANGLE CHISEL	1
10	760110	CYLINDER	1				
11	760111	O-RING	1				
12	760112	O-RING	1				
13	760113	O-RING	1				
14	760114	HANDLE	1				
15	760115	RUBBER GRIP	1				
						<b>OPTIONAL ACCESSORIES</b>	
					T-7601AH9	3/4" FLAT CHISEL	
					T-7601AH1	DIAMOND POINT CHISEL	